



Attachment R4

Erosion and Sediment Control Management Plan

May 2022

Vista Gold Australia Pty Ltd

Mount Todd Project Area



Table of contents

1	INTRODUCTION	1
1.1	Purpose	1
1.2	Objective	1
1.3	Acts, standards and guidelines	2
2	SITE CONDITIONS	3
2.1	Climatic conditions (Rainfall, temperature and wind)	3
2.2	Topography	8
2.3	Soils	8
2.4	Surface hydrology	8
2.5	Vegetation	9
3	EROSION AND SEDIMENT CONTROL DESIGN PHILOSOPHY	11
3.1	Introduction to design	11
3.2	Potential design options	15
3.3	Erosion control	15
3.4	Drainage Ccontrols	20
3.5	Sediment controls	30
3.6	Mulch filter berms	31
3.7	Stormwater retention basin	32
4	OVERVIEW OF EROSION AND SEDIMENT CONTROL MEASURES	35
4.1	Ground disturbance process	35
4.2	Mount Todd Project Area	36
4.3	Construction camp	40
5	MAINTENANCE REQUIREMENTS	41
6	MONITORING	45
7	REPORTING, AUDITING AND REVIEW	46
8	INCIDENT REPORTING	47

Table index

Table 2-1 Summary of Rainfall Data.....	4
Table 2-2 Katherine (km/h) and Mt Todd (m/s) Wind Speed Averages.....	7
Table 2-3 Stream Flow for the Major River Systems of the Daly River Catchment.....	9
Table 3-1 A Summary of Erosion Processes	12
Table 5-1 Erosion and Sediment Control Maintenance Requirements.....	42

Figure index

Figure 2-1. Average Wind Speed and Direction at Mt Todd from 2007 to 2016	6
Figure 3-1 A typical profile of a flow diversion bank (IECA 2008)	21
Figure 3-2 A typical Profile of a Parabolic Catch Drain without a bank (IECA 2008)	22
Figure 3-3 A Typical Profile of a Parabolic Catch Drain with a bank (IECA 2008).....	22
Figure 3-4 A Typical Profile of a Diversion Channel with a bank (IECA 2008)	24
Figure 3-5 Layout and Profile of a Rock Check Dam (IECA 2008).....	25
Figure 3-6 Typical Layout of a Level Spreader (IECA 2008)	26
Figure 3-8 Typical Profile and Layout of a Chute and Energy Dissipater (IECA 2008).....	29
Figure 3-9 and Plate 3-8 Example of Small Rock Shute and Dissipater off a Hardstand.	29
Figure 3-9 Typical Installation of a Sediment Fence (IECA 2008).....	31
Figure 3-10 Typical Profile and Recommended Maximum Spacing of a Mulch Filter Berm (IECA 2008)32	
Figure 3-11 Typical Profile of a Sediment Basin with Riser Pipe Outlet (IECA 2008)	34
Figure 3-12 Typical Plan View of a Sediment Basin with Riser Pipe Outlet and Energy Dissipater (IECA 2008).	34



1 Introduction

The Mount Todd Project Area (MTPA) is a brownfield/disturbed site that was historically mined for gold between the 1990s until 2000. The MTPA site is located approximately 55km northwest of Katherine and 250km south of Darwin. The area surrounding the mining lease is rural and sparsely populated. The Werenbun community is the closest residential area located approximately 6.5km from the site. The Stuart Highway, the main arterial road in the region, is located west of the mine.

Mining infrastructure such as tailing dams, waste rock dumps and the remains of processing facilities remain on site. MTPA will mine the site using conventional drill and blast, open-pit truck and shovels & excavator methods, using large haul trucks, hydraulic shovels, excavators and front-end loaders to transport material to the crusher, stockpiles, Run of Mine (ROM) pad and Waste Rock Dump (WRD).

MTPA, based on current known data will have a life of around 20 years inclusive of construction, operations and closure. Construction is anticipated to take two years. The mine is scheduled to operate for an additional 13 to 17 years, and closure and rehabilitation of the mine is expected to take four years.

1.1 Purpose

The Erosion and Sediment Control Management Plan forms part of the Environmental Management System (EMS) for the mine and is considered a working document. It has been updated following formal consultation and assessment by Department of Primary Industry and Resources (DPIR) as part of the mining authorisation process in 2020 and submitted as an updated plan May 2022 to Department of Industry, Tourism and Trade (DITT).

This ESCMP has been prepared to:

- Provide a high-level strategy for the management of erosion and sediment across the MTPA. The ESCMP covers the construction, operation and closure phases; and
- Inform the reader/contractor of Erosion and Sediment Control (ESC) design philosophy, and to establish measures for installation and maintenance activities.

1.2 Objective

The objective of this ESCMP is to minimise the potential for erosion and sedimentation during the construction, operation and closure phases through:

- Identifying areas that pose a risk of erosion and sedimentation as early as possible in the MTPA phases;
- Plan and develop ESC measures for identified areas;
- Engage professional expertise from the International Erosion Control Association (IECA) registered group of Certified Persons in Erosion and Sediment Control (CPESCs);



- Encouraging prompt rehabilitation of project construction, operational and closure areas through appropriate revegetation strategies; and
- Promote effective transfer of knowledge regarding erosion and sediment control between employees and contractors.

1.3 Acts, standards and guidelines

This ESCMP is based on the following standards and guidelines:

- Best Practice Erosion and Sediment Control for Building and Construction Projects (November 2008), International Erosion Control Association (IECA) Australasia
- Soil Conservation and Land Utilisation Act(1969)
- Erosion and Sediment Control Guidelines Built Environment, 2007, the former Department of Natural Resources, Environment and the Arts, Northern Territory Government
- Northern Territory Minerals Council (Inc.) and the Mines and Petroleum Management Division of the Northern Territory Government, 2004, TEAM NT: Technologies for Environmental Advancement of Mining in the Northern Territory: Toolkit, D.R. Jones and M. Fawcett, principal authors
- Erosion and Sediment Control Plans Fact Sheet, Land Management Unit, Natural Resources Division.

2 Site Conditions

The MTPA is susceptible to extreme weather events. Tropical cyclones occur over the wet season (October - April) due to low-pressure systems forming offshore over warm tropical waters. As the cyclone system moves around offshore, wind speeds can reach 270km/h or more within the storm centre. As these systems move inland they down grade to low pressure systems and can bring with it significant wind gusts and periods of torrential rain and numerous lightning strikes resulting in fires in the region.

2.1 Climatic conditions (Rainfall, temperature and wind)

The MTPA experiences a sub-tropical savannah climate with distinct Wet and dry seasons. Daily temperatures in the dry season typically range from 24°C - 36°C, occasionally reaching 39°C. Nights in the dry season can be quite cool with temperatures falling to 7°C. During the wet season, daily temperatures can range from 27°C - 42°C. High levels of humidity occur within the MTPA, with intensity reaching 80 - 100% between October and March. During this time, the region receives spectacular electrical storms along with vigorous lightning displays. Throughout the dry season (April – September), humidity levels can range from 50 - 70%.

Rainfall at the MTPA is generally characterised by infrequent and intense rainfall events. The mean annual rainfall that was recorded by the Mt Todd weather station between 2012-2017 was 1158.7mm.

Site specific meteorological data are collected by three automatic weather stations installed at the MTPA. The first was installed in March 2011 on the ridge to the west of the scats pile. The two additional weather stations were commissioned in December 2015. The first is situated SW of Batman Pit on the edge of the Yinberrie Hills escarpment and the second on the eastern edge of the main plant area in the accommodation compound. The weather station that is set up in the accommodation compound is going to be relocation in the future to another area a bit further away from the main area of activities. It is also proposed that another station will be set up N/W of the site.

The current onsite weather station was commissioned in mid-2011 to provide continuous on-site records for weather data in preference to relying on Katherine township data. The station is situated on the ridge to the west of the TSF1 scats pile. The weather station records the following meteorological parameters:

- Rainfall
- Wind Speed
- Wind Direction
- Solar Radiation
- Net Radiation
- Barometric Pressure
- Relative Humidity



- Air Temperature.

Monitoring of site meteorological conditions provided by daily observations and telemetered data from the Mt Todd Weather Station. These results are compared with Katherine Bureau of Meteorology data and presented in [Table 2-1](#) and [Table 2-2](#) and data from the weather station is available at the site in real time via the onsite telemetry network.

Table 2-1 Summary of Rainfall Data.

	Katherine Monthly Rainfall (mm)												Total Annual
	Jul	Aug	Sep	Oct	Nov	Dec	Jan	Feb	Mar	Apr	May	Jun	
2007-08	0.0	32.4	0.0	18	106	331	219	470	196	1.6	0.0	0.0	1374
2008-09	0.0	0.0	1.0	4.4	58	399	436	308	10	0.0	0.0	0.0	1216
2009-10	0.0	0.0	0.2	0.6	21	291	343	214	107	57	12	0.0	1046
2010-11	0.0	3.8	19	77	65	419	268	360	236	228	0.0	0.0	1675
2011-12	0.0	0.0	0.0	30	201	247	98	202	358	48	1.8	0.0	1186
2012-13	0.0	0.0	14	0.0	120	173	188	165	389.	103	0.0	0.1	1152
2013-14	0.0	0.0	0.0	14	143	166	282	327	111	27	0.0	0.0	1070
2014-15	0.0	0.0	0.0	2.0	93	291	209	107	134	0.0	8.2	0.0	845
2015-16	0.0	0.0	0.0	0.0	97	597	252	113	101	19	45	0.0	1222
2016-17	5.2	0.0	58	4.4	41	122	470	322	319	22	0.0	0.0	1365
2017-18	0.0	5.2	0.0	12	140	166	431	298	21	0.0	0.0	0.0	1073
2018-19	0.0	0.0	0.0	15	192	221	267	172	99	41	0.6	0.0	740
2019-2020	0.0	0.0	0.0	0.0	14	46	182	123	29	61			454
1943-2020 (Average)	0.1	1.4	5.9	30	90	217	267	234	193	43	4.7	0.4	1135
Mt Todd Weather Station Monthly Rainfall (mm)													
2012-13	0.0	0.0	7.0	0.7	130	217	116	248	331	151	29	0.2	1230
2013-14	0.0	0.0	2.0	35	253	187	319	341	90	6.1	3.0	0.0	1235
2014-15	0.0	0.0	0.0	2.7	109	175	244	134	121	0.2	8.6	0.5	794
2015-16	0.0	0.0	0.0	58	90	549	288	103	130	4.4	39	0.0	1261
2016-17	4.9	0.0	21	9.7	85	236	442	213	203	47	0.0	0.0	1262



	Katherine Monthly Rainfall (mm)												Total Annual
	Jul	Aug	Sep	Oct	Nov	Dec	Jan	Feb	Mar	Apr	May	Jun	
2017-18	0.0	0.0	0.0	11	180	141	540	132	91	8.9	0.0	0.0	1104
2018-19	0.0	0.0	0.0	29	176	58	351	123	80	32	0.1	0.0	849
2012-2017 Average	1.0	0.0	5.9	21	133	273	282	207.5	175	40	20	0.2	1159

Notes: Rainfall data from Katherine Aviation Museum for 2007-2012 & 2018-2020 (14903) and Katherine Country Club for 2012-2018 (14905).

2.1.1 Wind

Wind direction and speed has been monitored on-site from 2011 when an AWS was installed. Wind illustrates distinct seasonality, with the dry season dominated by south-easterly trade winds and the wet season dominated by north westerlies as an effect of the Australian Monsoon. Stronger wind is experienced during the dry season within wind speed between 0 – 8 m/s recorded whilst during the dry season wind speed between 0 – 5.5 m/s. A summary of the annual wind direction and strength, as well as seasonal summaries, is presented as wind roses in **Figure 2-1**.

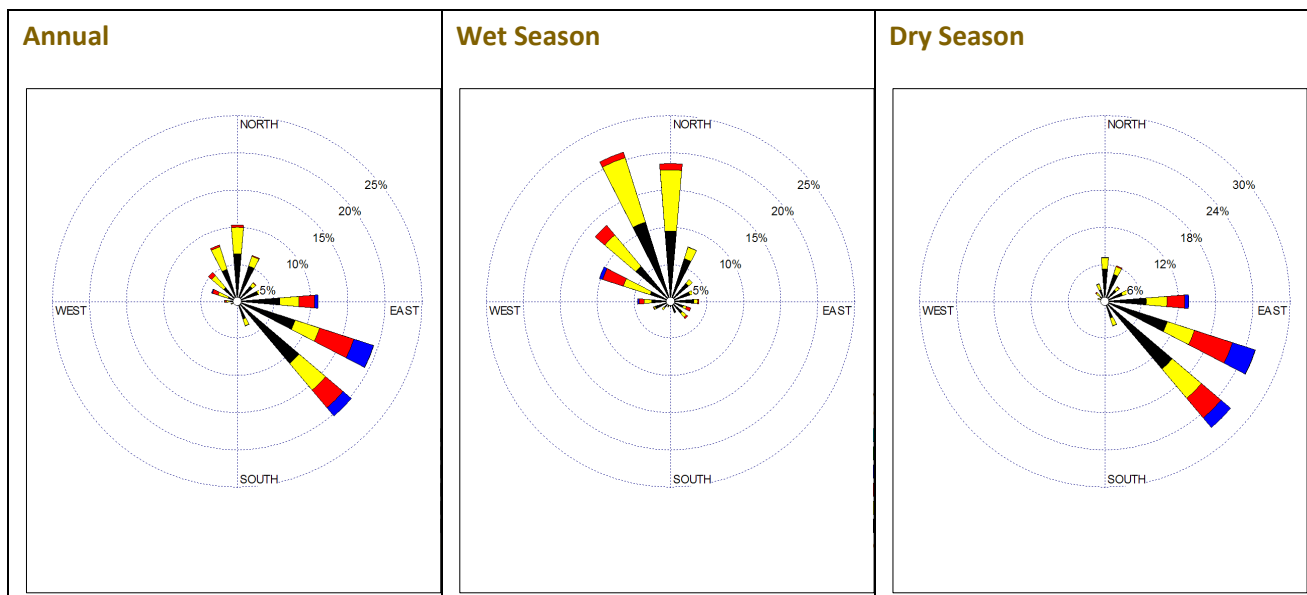

Figure 2-1. Average Wind Speed and Direction at Mt Todd from 2007 to 2016

TABLE 2-3 details average wind speeds from Katherine (2012 – 2016) and Mt Todd (2012 – 2016).



Table 2-2 Katherine (km/h) and Mt Todd (m/s) Wind Speed Averages.

Katherine Wind Speed Averages (km/h)																									
	Jan		Feb		Mar		Apr		May		Jun		Jul		Aug		Sep		Oct		Nov		Dec		
	9am	3pm	9am	3pm	9am	3pm	9am	3pm	9am	3pm	9am	3pm	9am	3pm	9am	3pm	9am	3pm	9am	3pm	9am	3pm	9am	3pm	
2012	24.5	34.7	24	35.4	23.8	32.9	19.9	33.7	19.6	34	14.2	26.8	10.6	29.3	14.6	31.2	18.3	35.8	23.3	37.8	24.4	37.7	24	35.7	
2013	24	34.7	23.9	32.7	22.6	33.6	16.3	33.4	13.1	31.3	14.3	30	11.3	30.1	14	31.4	20.4	36.3	22.7	38.5	25.4	38.4	24.3	34.5	
2014	23.8	33.6	23.8	32.6	21.1	35.3	20.6	35.3	17	31.8	13.8	31.2	12.2	30.3	14.8	33.5	21.5	36.8	22.6	37.8	25.4	38.9	24.8	36.4	
2015	24.4	34	24.5	34.6	22.9	33.8	22.8	33.5	21.1	32.3	14.1	29.6	17.8	31.2	16.2	32.8	22.9	36.1	23.1	35.7	23	36.1	23.9	34.8	
2016	24	33.2	23.7	32.2	23.8	31.8	20.1	31.4	14	29.7	9.2	27.6	13.5	29.8	13.2	31.5	17.4	34.8	23.9	37.3	24.2	35.6	24.6	35.3	
Mt Todd Weather Station Wind Speed Averages (m/s)																									
2012	-	-	-	-	-	-	-	-	-	-	-	-	-	11.9	13.6	7.3	14.9	8.5	13.9	10.5	11.1	7.4	11	5.8	7.6
2013	7.7	10.9	5.4	7.7	6.9	9.4	7.2	13.5	10.9	13.5	11.5	14.1	10.2	15.9	7.1	14.5	9.4	12.8	8.6	12.8	6.8	11.3	5.7	8.5	
2014	7.3	10.1	8.2	11	5.7	11.3	6.5	12.7	7.9	13.3	12.6	15.9	6.9	13.4	13.5	16.1	6.6	12.6	8.1	14.9	8	9.8	7.3	8.6	
2015	9.1	11.6	5.9	10.4	6.4	10.1	9.5	12.1	10.4	14.1	8.3	15.8	2.55	4.15	2.48	3.57	2.89	4.18	2.33	4.01	1.88	2.61	2.16	2.88	
2016	1.64	2.86	1.45	2.57	1.42	1.92	1.55	4.14	1.94	3.5	2.83	3.25													

2.2 Topography

The MTPA Mineral Leases are located in the Daly River Catchment and comprises mostly foothills located west of the western Arnhem Land sandstone massif. The MTPA is situated between Mt Todd (230m AHD) to the east, the Yinberrie Hills to the west, hills to the north and less undulated ground to the south. Various creeks surrounding the MTPA flow in a generally southerly direction towards the Edith River located along the southern boundary of the lease. The main natural topographic feature of the MTPA with an elevation of 230m. The MTPA has an elevation of approximately 130 to 160m above sea level.

2.3 Soils

Throughout the MTPA, soils vary from sandy and loamy red and yellow earths to lateritic and yellow podsollic soils on gently undulating land, often over compacted clay sub-soils. Heavier textured grey soils are found on the floodplains and levees of the Daly River system while stony and skeletal soils occur in the hills. The MTPA's soils reflect that of the broader area.

In 2012 a geotechnical investigation was undertaken to look for suitable soils for building embankments. It was identified that over the site material was found to be variable and ranged from very high to very low dispersive potential. For the purpose of erosion and sediment control a precautionary approach has been undertaken and it is assumed that the soils are dispersive following disturbance.

2.4 Surface hydrology

The MTPA Mineral Leases are located in the Daly River Catchment and comprises mostly foothills located west of the western Arnhem Land sandstone massif. The natural hydrology of the mine site is dominated by the perennial Edith River and its tributaries. The Edith River stream gauge has had recorded measurable flow approximately 70% of the time. During dry years the riverbed has been observed to go dry, however, even when the surface flow is not measurable, there is subsurface flow through the underlying alluvium. The creeks feeding the Edith River are ephemeral.

2.4.1 Watercourses

The Daly River is one of the Northern Territory's largest rivers with a catchment area of 52,577 km². It is one of a few catchments in the Northern Territory that has perennial flow. Five main tributary river systems are located within the Daly River Catchment; Katherine River, Flora River, Fergusson River, King River and Douglas River. Of the five main tributary river systems, the Fergusson River is closest to the mine site, located approximately 15 km to the northwest. The Fergusson River is 144 km in length and has several creeks and rivers as tributaries, of which the Edith River is the largest. The Edith River is located immediately south of the MTPA.

Surface run-off and flow into local creeks occurs during the wet season. Five ephemeral creeks (Horseshoe, Batman, Burrell, West and Stow) as located within the mining lease. The Batman and Horseshoe creeks flow in to Stow Creek which in turn flows into the Edith River. The West and Burrell creeks flow directly into the Edith River. A summary of stream flow for the major river systems of the Daly River Catchment is in [Table 2-3](#) below.

Table 2-3 Stream Flow for the Major River Systems of the Daly River Catchment.

Gauging station number	River	Catchment area (km ²)	Mean annual flow volume (m ³)	Mean annual discharge (m ³ /sec)
G8140040	Daly River	47,100	5,750,000,000	213.90
G8140001	Katherine River	8,640	1,922,000,000	87.17
G8140044	Flora River	5,900	762,300,000	30.80
G8140008	Fergusson River	1,490	415,600,000	23.49
G8140068	King River	11,000	207,800,000	7.64
G8140063	Douglas River	842	148,800,000	6.07

2.5 Vegetation

The MTPA is located in the Pine Creek Bioregion. It is a region of mostly foothills located west of the western Arnhem Land sandstone massif. It is dominated by Darwin stringybark (*Eucalyptus tetradonta*) and Darwin woollybutt (*E. miniata*) open forest, eucalypt woodlands, riparian vegetation associated with waterways and some patches of monsoon thicket.

Vegetation in the Pine Creek Bioregion is well conserved with at least 12,124km² or 42.6% under conservation management in national parks and reserves (NRETA 2005). This includes large areas in Kakadu, Nitmiluk, Litchfield and Mary River National Parks. The Mineral Leases lie within part of the Yinberrie Hills Site of Conservation Significance (SOCS). The designation of the area as a SOCS is largely based on the presence of threatened fauna and their habitats.

The MTPA encompass a variety of habitats forming part of the northern savannah region, which is characterised by Eucalypt woodland with tropical grass understoreys. Eight vegetation types were mapped in the Mineral Leases at 1:50,000 including two degraded vegetation communities.

1. Melaleuca forest, with bare areas
2. *Eucalyptus Bigalerita*, *Eucalyptus spp.* open-forest
3. *E. tintinnans Eucalyptus spp. Erythrophleum chlorostachys* woodland
4. *E. tintinnans, Corymbia dichromophloia* woodland
5. *E. tectifera* woodland



6. *E. tectifera*, *C confertiflora* woodland
7. *E. latifolia* *E. bigalerita* open-woodland with areas of grassland
8. *E. tectifera* woodland\ *E. tintinnans* *Eucalyptus* spp. *Erythrophleum chlorostachys* woodland

The dominant communities in the area of the mine prior to its development were the *E. tintinnans* dominated woodlands in rocky hills and *E. tectifera* dominated woodlands in the surrounding plains. Previous development of the site resulted in reductions of the extent of the *E. tintinnans* woodlands and the *E. tectifera* woodlands within the mine site.

3 Erosion and Sediment Control Design Philosophy

Temporary and permanent erosion control techniques are used to prevent controllable erosion and to minimise the adverse effects of sedimentation. Good erosion control techniques decrease the dependence on sediment controls and potentially reduce the long-term costs associated with the site. Strategies to minimise the risk of erosion on site include:

- Planning (sequence/stage) construction works to limit the extent of exposure of exposed earth;
- Minimising the velocity or water runoff;
- Minimising erosive effects of water and wind (raindrop impact protection and surface water velocity) on exposed soils;
- Stabilising disturbed areas as soon as possible with the use of grassing or as prescribed. If soil erosion is identified in an exposed area, it will be stabilised using mulch, or a stabilising product; and
- Diversion of receiving waters around works.

3.1 Introduction to design

Soil erosion can occur through several individual or combined processes. In general, soil erosion is driven by water, wind or physical disturbance which causes particles to become displaced. It can be natural erosion or accelerated human-induced erosion. A summary of erosion processes is provided in Table 3-1.



Table 3-1 A Summary of Erosion Processes

Aspect	Forms of Erosion	Description	Factors Affecting Erosion
Water Erosion	Splash Erosion (raindrop)	The spattering of soil particles caused by the direct impact of precipitation onto an exposed surface. The soil particles are typically moved distances up to 1m when initially dislodged. These particles may subsequently be transported by surface water runoff. Splash erosion is minimised if soils/tailings/residue storage facilities have a water coverage greater than 2mm.	<p>The factors which affect water erosion include:</p> <ul style="list-style-type: none"> • Soil with low surface cover; • Shallow surface soils overlying low permeable subsoils/rock; • Surface soils with high percentage of fine sand or silts; • Surface soils that are hard setting or have a surface crust; • Soils with low levels of organic matter; and • Soil with dispersive properties.
	Sheet Erosion (including splash erosion)	Uniform removal of soil in thin layers from sloping land. Sheet erosion is minimised through stabilisation of surfaces through practices such as revegetation.	
	Rill Erosion	Rill erosion generally occurs by the removal of soil by water concentrated into small defined channels on sloping land. Rills can be up to 300mm deep. Rill erosion is minimised through stabilisation of surfaces through practices such as revegetation.	
	Gully Erosion	Gully erosion is similar to rill erosion but produces deeper channels generally greater than 300mm.	
	Tunnel Erosion	Tunnel erosion is the removal of subsoils in a sub-surface tunnel (i.e. out of sight). It generally occurs near gullies, creek lines or constructed embankments in dispersive soils or where a weak drainage path is already present.	
	Watercourse Erosion	Watercourses naturally transfer sediments downstream. However, a modification of stream banks often leads to instability and erosion.	
Wind Erosion	Surface Creep	Rolling and sliding of large particles (>1mm) which are too heavy to be lifted in the air. The particle rolls and dislodges other soil particles by hitting into them.	<p>The factors which affect wind erosion include:</p> <ul style="list-style-type: none"> • Soil with low surface cover;



Aspect	Forms of Erosion	Description	Factors Affecting Erosion
	Saltation	Wind directly causing particles generally with a diameter of 0.1 to 0.5mm to hop and bounce across the surface. The particle then dislodges other particles on impact.	<ul style="list-style-type: none">• Dry and High/consistent wind environments; and• Soil characteristics including its binding potential and surface roughness.
	Suspension	Movement of small dust (<0.1mm) particles into the air. The particles can rise high above the ground and form severe dust storms.	

3.2 Potential design options

Selection of drainage, erosion and sediment treatment measures is based on the following principles of effective erosion and sediment control:

- Minimise the extent and duration of soil disturbance;
- Control the location and velocity of drainage flow;
- Minimise soil erosion initiated by wind, rain or concentrated flow;
- Minimise sediment flow from the MTPA;
- Promptly revegetate/stabilise all exposed and/or unstable soil surfaces; and
- Appropriately install, operate and maintain all ESC measures.

3.2.1 Design parameters

The extent and type of erosion control measures depends on the likelihood and intensity of expected rainfall and sheet flow. The treatments and approaches in this ESCMP are divided into three categories of control measures including:

- Erosion control measures are designed based on average monthly rainfall ranging from 0mm in August to 282mm in January;
- Drainage Control Measures; and
- Drainage and sediment control measures are designed primarily based on the Average Recurrence Internal (ARI) of the design storm which is 1:100 year 72 hour rainfall event.

3.3 Erosion control

Erosion control measures are to minimise movement and loss of sediments at the source. Good erosion control techniques decreases the dependence on sediment controls and potentially reduce the long-term costs associated with the MTPA. Typical measures include:

- Minimise the area and duration of disturbance;
- Minimise soil and stockpile erosion caused by wind and rain; and
- Minimise turbidity levels in stormwater runoff by minimising the exposure of soil to rain and stormwater flow.

3.3.1 Planning construction/clearance works

The following measures are recommended during planning and preparation of construction works:

- Avoid placing stockpiles near boundary of clearings to limit the area of impact of runoff;

- Stockpiles will not be established within ecologically or culturally sensitive areas, floodplains or within 20m of a watercourse or drainage channels;
- Soils around stockpiles will be re-levelled to minimise sedimentation;
- Disturbed areas will be stabilised progressively e.g. with vegetation/cellular confinement system/mulch during construction where necessary;
- Stockpiles will be sprayed as required by the watercart to minimise dust emissions; and
- Erosion and sediment control measures will not be removed until disturbed areas have been stabilised.

3.3.2 Flagging

Flagging should be installed at all locations to be cleared to ensure the areas are not over cleared. The maintenance of vegetation adjacent to clearing assists in reducing any surface water runoff volume and velocity.

3.3.3 Revegetation

Vegetation or revegetation provides:

- Physical protection against raindrop impact;
- Barrier between the earth and flow;
- Increased surface roughness that reduces erosive flow velocities; and
- Increased absorption of rainfall by the soil-profile, reducing the volume of runoff.

Revegetation will be carried out on disturbed soil surface that has the potential to erode and cause sediment movement into the surrounding environment during rain events. Revegetation is an effective long-term ESC measure. Ideally, plants should be native to the area, have good soil binding capability and compete successfully with weed species.

Topsoil will be collected during the disturbance and applied across areas to be revegetated. Vegetation cleared will be mulched and stockpiled during the clearing process and stored for use during rehabilitation.

For more details on revegetation refer to:

- Catchments & Creeks fact sheet on revegetation: http://www.catchmentsandcreeks.com.au/fact-sheets/fs_erosioncontrol_natural.html.
- The International Erosion Control Association (IECA) Australasia publications on revegetation – general: <https://www.austieca.com.au/publications/erosion-control>.

3.3.4 Gravel sheeting

Gravel sheeting provides a permanent erosion control from raindrop, wind and potential mud generation impacts. It is ideal for application on areas of broad, low gradient earth surfaces and can be used in high traffic volume areas. In general gravelling will be utilised at site offices/administration buildings, across the accommodation village and dedicated light vehicle parking areas.

Application of gravel to the Project compounds provides:

- Physical protection against raindrop impact;
- Barrier between the earth and flow;
- Increased surface roughness that reduces erosive flow velocities; and
- Increased absorption of rainfall by the soil-profile, reducing the volume of runoff.

Gravel should be approximately 20 – 75mm hard, angular, weather resistant and evenly graded. It should be applied to a minimum of 50mm thickness across the designated area. Reapplication of gravel will be undertaken as required following maintenance inspections.

It should be noted that if gravel continually migrates off dedicated location a cellular confinement system (CCS) may be installed to restrict lateral displacement.

For more details on gravelling refer to:

- Catchments & Creeks fact sheet on gravelling: http://www.catchmentsandcreeks.com.au/fact-sheets/fs_erosioncontrol_natural.html.
- The International Erosion Control Association (IECA) Australasia publications on gravelling: <https://www.austieca.com.au/publications/erosion-control>.

3.3.5 Cellular confinement system.

CCSs (*Plate 3-1 & Plate 3-2*) are utilised to hold soils or gravels in place thereby restricting potential erosion. The material is an expandable, three-dimensional open honeycomb mesh. The mesh is installed at flush or slightly below the existing ground surface. If it is to be installed on a slope steeper than 10% it will be anchored into a trench along the top of the treatment area (200 mm deep and 500 mm wide). CCS may be used when:

- Gravelling applied is migrating from dedicated location;
- Gravelling is applied to an area which is not evenly graded;
- Sandy riverbeds are encountered at temporary watercourse crossing (fords); and
- Steep slopes require vegetation to be established as the CCS can hold the soils in place.

For more details on cellular confinement systems refer to:

- Catchments & Creeks fact sheet on cellular confinement systems:
http://www.catchmentsandcreeks.com.au/fact-sheets/fs_erosioncontrol_Synthetic.html
- The International Erosion Control Association (IECA) Australasia publications on cellular confinement systems : <https://www.austieca.com.au/publications/erosion-control/>.



Plate 3-1 An example of cellular confinement system used to restrict gravel movement on a carpark.



Plate 3-2 An example of cellular confinement system used to retain soil and assist in the establishment of grass

3.3.6 Dust control – watercart

Ground conditions are generally dry and traffic movements and wind energy has the potential to erode unsealed tracks, haul roads and topsoil stockpiles. Watercarts will be used to suppress dust particles.

For more details on gravelling refer to:

- Catchments & Creeks fact sheet on dust control:
http://www.catchmentsandcreeks.com.au/fact-sheets/fs_erosioncontrol_Synthetic.html.

3.3.7 Soil binders

Soil binders can be used to stabilise soil and reduce erosion in areas where revegetation is not appropriate and/or if protection of the soil is time critical. Soil binders provide:

- Physical protection against raindrop impact; and
- Barrier between the earth and flow.

For more details on soil binders refer to:

- Catchments & Creeks fact sheet on soil binders http://www.catchmentsandcreeks.com.au/fact-sheets/fs_erosioncontrol_Synthetic.html.

- The International Erosion Control Association (IECA) Australasia publications on bonded fibre matrix: <https://www.austieca.com.au/publications/erosion-control>.

3.3.8 Surface roughening/contour ripping

Surface roughening on exposed or revegetated surfaces increases erosion protection of soil surfaces by increasing water infiltration, delaying the formation of rilling and reducing dust generation. In order to roughen surfaces, machinery will be utilised. *Plate 3-4* and *Plate 3-3* shows examples of roughening and ripping.

Ridges will be installed along contours and perpendicular to the predominant wind directions (northwest and southeast) where possible. In general, ridges will be ripped to a depth of 600mm to 900mm in pairs approximately 2m to 6 m apart.

The installation will include the diversion of up-gradient stormwater runoff around the roughening areas. Following roughening/ridge installation the areas will be immediately seeded and mulched to optimise seed germination and growing conditions.

For more details on surface roughening/contour ripping refer to:

- Catchments & Creeks fact sheet on surface roughening: http://www.catchmentsandcreeks.com.au/fact-sheets/fs_erosioncontrol_natural.html.
- The International Erosion Control Association (IECA) Australasia publications on surface roughening: <https://www.austieca.com.au/publications/erosion-control>.



Plate 3-3 An example of a roughened slope



Plate 3-4 An example of contour ripping

3.4 Drainage Controls

Drainage control measures are principally used to:

- Divert 'clean' up-slope water around any soil disturbances; and
- Contain and transport potentially contaminated stormwater through disturbed areas to treatment measure(s), minimising contact with erodible soils.

Open channels are economical where large flows are to be carried and space is not restricted. Open channels provide for the continuous collection of surface runoff. Open unlined drains and v drains are generally not acceptable, all drains must be stabilised and preferably vegetated.

Bunds are utilised to divert or contain flow. Flow can be contained on a natural surface by a raised bund formed by raising compacted earth on the surface.

Channel or bund lining (e.g. rock, vegetation) is specified to protect the subsoil from erosion.

3.4.1 Flow diversion banks

Flow diversion banks are earth embankments which divert up-slope stormwater runoff from entering the disturbed area. Water collected by a flow diversion bank is transferred to a stable outlet structure (i.e. level spreader). The diversions are capable of containing dispersive subsoil due to the construction methodology not generally requiring the exposure of subsoils. Design considerations include:

- Discharge to a stable outlet;

- Drain sediment trap if the diverted water is expected to be contaminated;
- Not divert or concentrate flows onto an adjacent property; and
- Sides of the bank are to be not steeper than 2:1 (H:V) slope and the completed bank must be at least 500mm high (Figure 3-1).

Flow diversion banks at the MTPA will be stabilised immediately following initial construction (seeded, mulched and CCS where appropriate).

For more details on flow diversion banks refer to:

- Catchments & Creeks fact sheet on flow diversion banks:
http://www.catchmentsandcreeks.com.au/fact-sheets/fs_Other_drainage_Structures.html.
- The International Erosion Control Association (IECA) Australasia publications on flow diversion banks: <https://www.austieca.com.au/publications/drainage-control>.

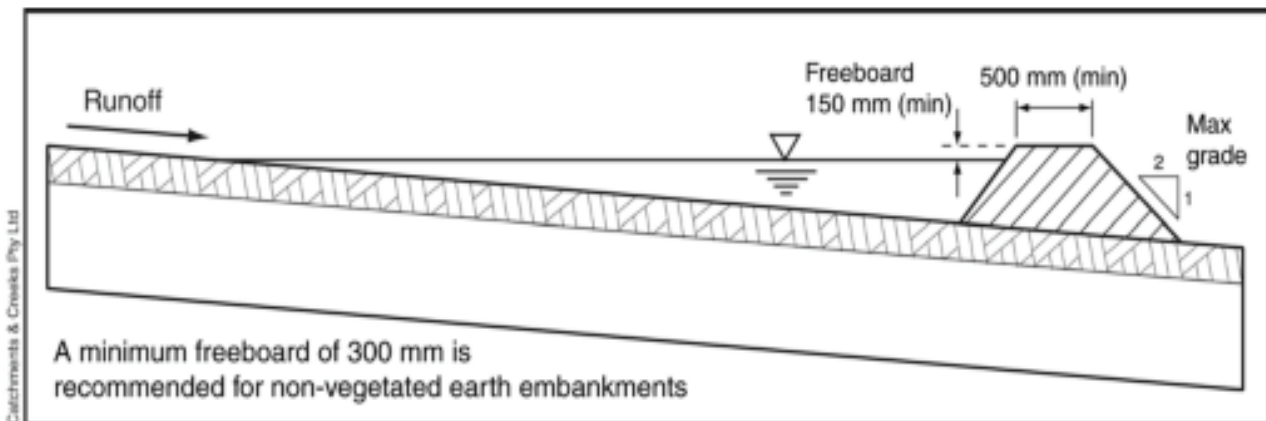

Figure 3-1 A typical profile of a flow diversion bank (IECA 2008)

3.4.2 Catch drains

Catch drains (**Error! Reference source not found.**) are channels excavated to divert flow around disturbed areas, and drain run-off away from erosion prone areas. They may be constructed across a slope to convey runoff at a non-erosive velocity. The channel may be combined with an embankment on the downslope side to increase its capacity (Figure 3-3). The drains intercept the sheet runoff and divert it at a non-scouring velocity to a stabilised outlet.

A typical gradient of a catch drain is 0.5% and may be as low as 0.25% or as high as 0.75%. As a general rule, the deeper the flow, the lower the maximum gradient. Use of rock-check dams can reduce the effective channel gradient of steeper channels by typically 5%. Catch drains are typically lined with either earth, grass, mat or rock.

For more details on flow diversion banks refer to:

- Catchments & Creeks fact sheet on catch drains:
- http://www.catchmentsandcreeks.com.au/fact-sheets/fs_drainage_catchdrains_chutes.html.
- The International Erosion Control Association (IECA) Australasia publications on flow diversion banks: <https://www.austieca.com.au/publications/drainage-control>.

Figure 3-2 A typical Profile of a Parabolic Catch Drain without a bank (IECA 2008)

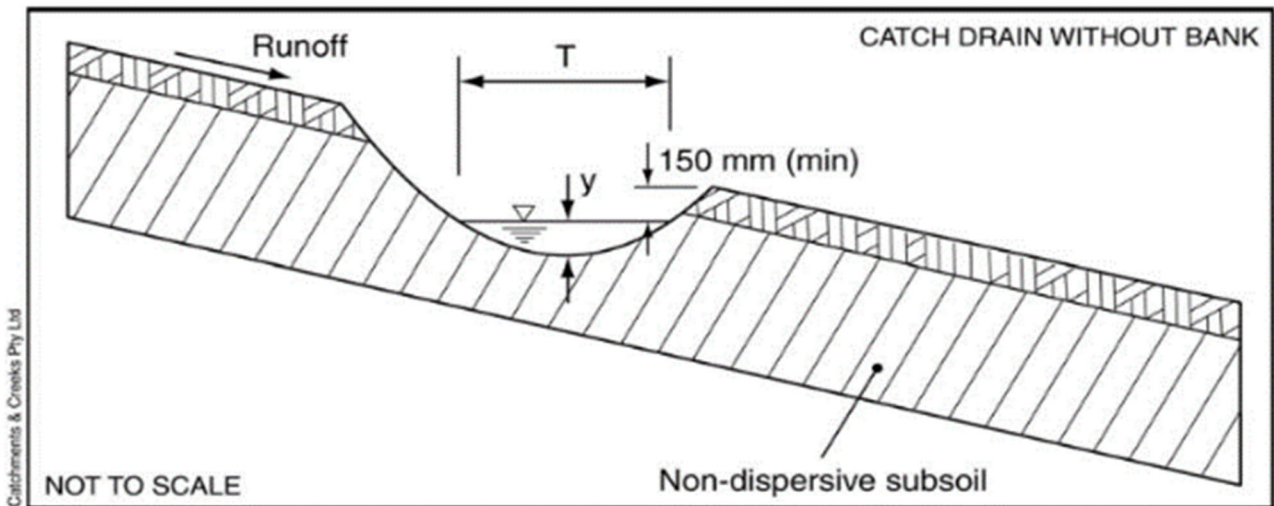
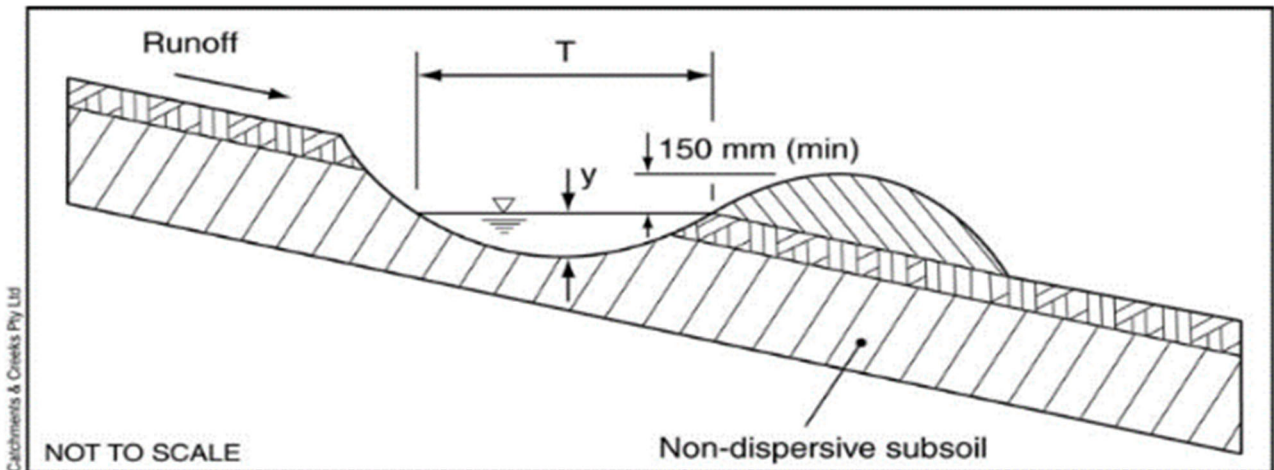

Figure 3-3 A Typical Profile of a Parabolic Catch Drain with a bank (IECA 2008).



3.4.3 Table drains

Table drains are constructed adjacent to sealed and unsealed roads to provide a preferential pathway for drainage. Table drains receive sheet flow from the surrounding environment and the formed road. The drains should be constructed with a clay base at least 300 mm deep. Where clearing allows the flat bed of the drain should be 2.5 m wide to facilitate maintenance activities. Table drains will have check dams installed to reduce water velocities and will discharge into a diversion drain.

3.4.4 Diversion channels

Diversion channels are constructed drainage channels which collect water from table drains and direct it to a suitable disposal area. Similar to a table drain they will be flat bottomed and will collect flows at grade (Figure 3-4



& Plate 3-5). The drains are to discharge water via a level spreader or the final grade should be 0.2% for 30 m (i.e. 6 cm fall over 30 m). The positioning of diversion drains is site specific but generally should be at a maximum of 120 m at slopes up to 2% reducing to 15 m for slopes greater than 8%.

For more details on diversion channels refer to:

- Catchments & Creeks fact sheet on diversion channels:
http://www.catchmentsandcreeks.com.au/fact-sheets/fs_Other_drainage_Structures.html.
- The International Erosion Control Association (IECA) Australasia publications on diversion channels: <https://www.austieca.com.au/publications/drainage-control>.

Figure 3-4 A Typical Profile of a Diversion Channel with a bank (IECA 2008)

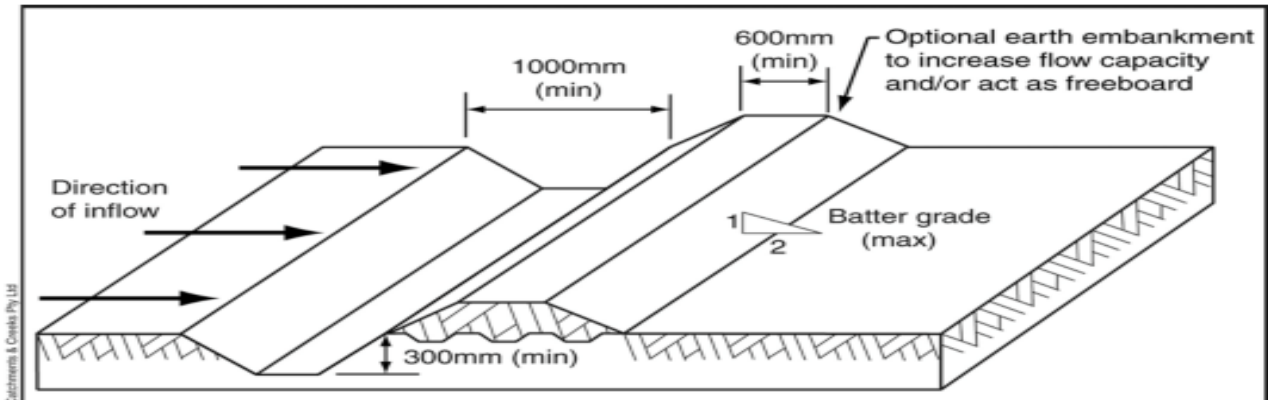

Plate 3-5 Example of Diversion Channel and Rock Armoured Outlet.



3.4.5 Check Dams

Check-dams control the flow velocity in channels. They are also effective at removing coarse sediments from stormwater flow. They can be constructed using either sandbags or rock. Rock material should be a minimum of 200 mm in size to reduce the risk of dam movement.

Check-dams are placed at intervals within the channel to create ponding of flow along the channel's length, between the toe of the upstream dam and overflow-invert of the downstream dam. This reduces the flow velocity, decreasing scour of the channel and allows coarse sediments to settle. Design criteria includes:

- Dam centre to be at least 150 mm lower than the edges, and dam height limited in height to around 0.5 m. Greater heights require a larger rock-apron to dissipate energy of the overflow (Figure 3-5 & Plate 3-6)

- Maximum spacing between the dams occurs where the toe of the upstream dam is at the same elevation as the crest of the downstream dam.

For more details on check dams refer to:

- Catchments & Creeks fact sheet on check dams:
http://www.catchmentsandcreeks.com.au/fact-sheets/fs_Other_drainage_Structures.html.
- The International Erosion Control Association (IECA) Australasia publications on check dams:
<https://www.austieca.com.au/publications/drainage-control>.

Figure 3-5 Layout and Profile of a Rock Check Dam (IECA 2008).

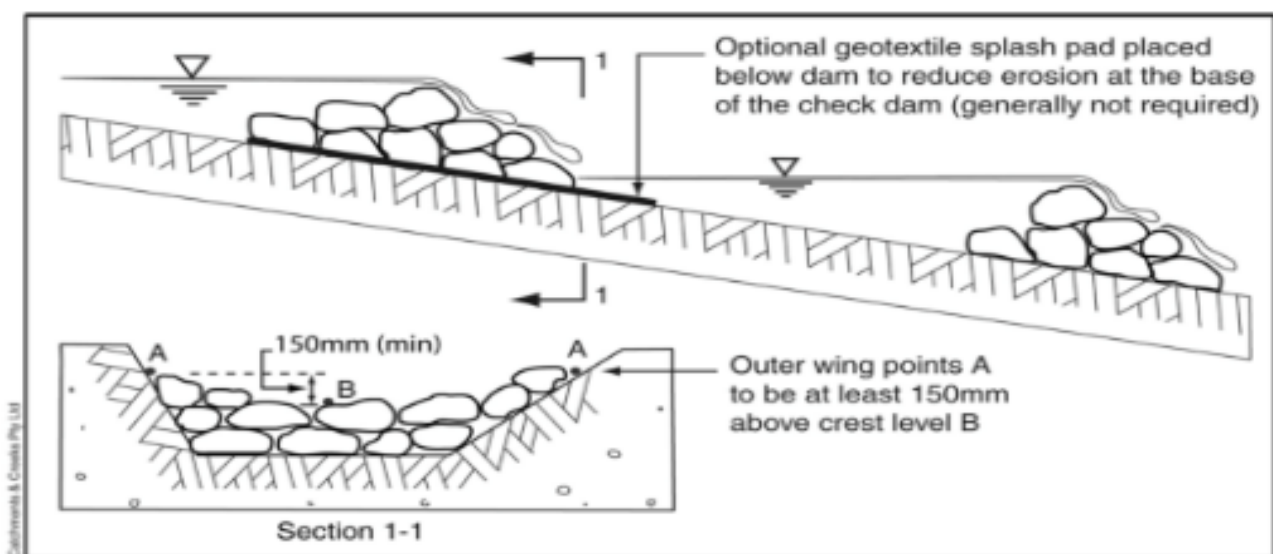

3.4.6 Level spreaders

Level spreaders are typically constructed along contour line and consist of a level rock protected entry, allowing concentrated flow to spread to a nominated flow width. Level spreaders are used on the outlet of diversion channels and basins to spread flow and convert concentrated flow into sheet flow (Figure 3-6 & Plate 3-7). Key issues are noted below:

- Level spreader outlet grade must be less than 10% and ideally discharge should occur to areas of undisturbed land;
- Typical maintenance, such as periodic checks, should be conducted to ensure that sediment build up and general erosion such as scouring or channel damage upstream and downstream of the spreader, does not occur; and
- Protection of the outlet can be achieved using jute mesh, grass turf, rock or other appropriate stabilisers.

For more details on level spreaders refer to:

- Catchments & Creeks fact sheet on level spreaders:

http://www.catchmentsandcreeks.com.au/fact-sheets/fs_Other_drainage_Structures.html.

- The International Erosion Control Association (IECA) Australasia publications on level spreaders :

<https://www.austieca.com.au/publications/drainage-control>.



Plate 3-6 Example of Rock Check Dam and Rock Dissipater

Figure 3-6 Typical Layout of a Level Spreader (IECA 2008)

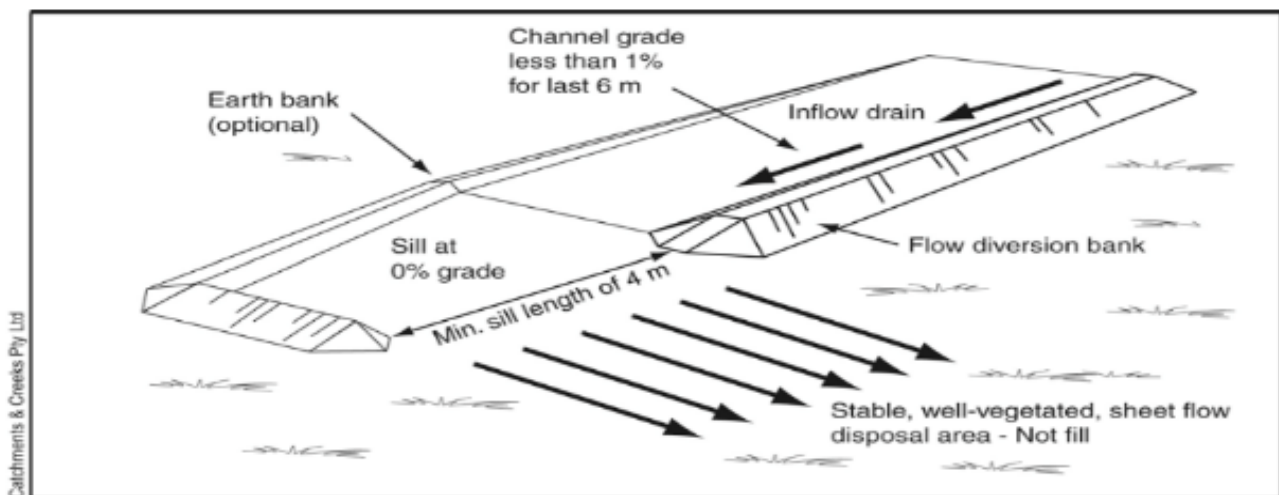

Plate 3-7 Example of Level Spreader Structure



3.4.7 Temporary watercourse crossings

Temporary ford crossings are constructed at watercourses or major drainage lines to facilitate traffic movements. The crossings are constructed and maintained in a manner which minimises impacts to watercourses and associated habitat value.

Key design details include:

- Constructed at the existing watercourse bed level on a straight section of the watercourse;
- Approach roads should be straight for a minimum of 10 m prior to the crossing and be stabilised;
- Road drainage will be installed to transfer flows away from the crossing; and
- Sandy riverbeds can be stabilised using a geo-grid or cellular confinement system.

For more details on temporary ford crossings refer to:

- Catchments & Creeks fact sheet on temporary ford crossing:
http://www.catchmentsandcreeks.com.au/fact-sheets/fs_Other_drainage_Structures.html.
- The International Erosion Control Association (IECA) Australasia publications on temporary ford crossing: <https://www.austieca.com.au/publications/drainage-control>.

3.4.8 Rock lined chute

Chutes provide a stable pathway for the transfer of water from elevated surfaces such as rehabilitated Waste Rock Dumps, Flotation Tailings Storage Facility and Residue Storage Facility to ground level (Figure 3-7).

Key design details include:

- Surface drainage across an elevated structure to be directed toward chute(s);
- Installation of rock mattress or alternative stable landform at the base to control erosion;
- Chute to be designed with a safety factor of 1.5 (high risk structure); and
- Rock to be geochemically stable, durable and resistant to weathering.

For more details on rock lined chutes refer to:

- Catchments & Creeks fact sheet on chutes: all 5 parts:
http://www.catchmentsandcreeks.com.au/fact-sheets/fs_drainage_catchdrains_chutes.html.
- The International Erosion Control Association (IECA) Australasia publications on rock lined chutes:
<https://www.austieca.com.au/publications/drainage-control>.

3.4.9 Energy dissipater and recessed rock pad (outlet structure)

Energy dissipaters provide outlet control for rock lined chutes to prevent undermining of the chute and control scour immediately downstream (Figure 3-7 & Figure 3-8 and Plate 3-8). The dissipater itself will be made of coarse riprap or rows of small concrete impact blocks to form as bed roughness and will lead into a recessed rock pad to allow sheet flow to the surrounding environment.

For more details on energy dissipaters and recessed rock pads refer to:

- Catchments & Creeks fact sheet on energy dissipaters:
- http://www.catchmentsandcreeks.com.au/fact-sheets/fs_Other_drainage_Structures.html.
- The International Erosion Control Association (IECA) Australasia publications on chutes:
<https://www.austieca.com.au/publications/drainage-control>.

Figure 3-7 Typical Profile and Layout of a Chute and Energy Dissipater (IECA 2008).

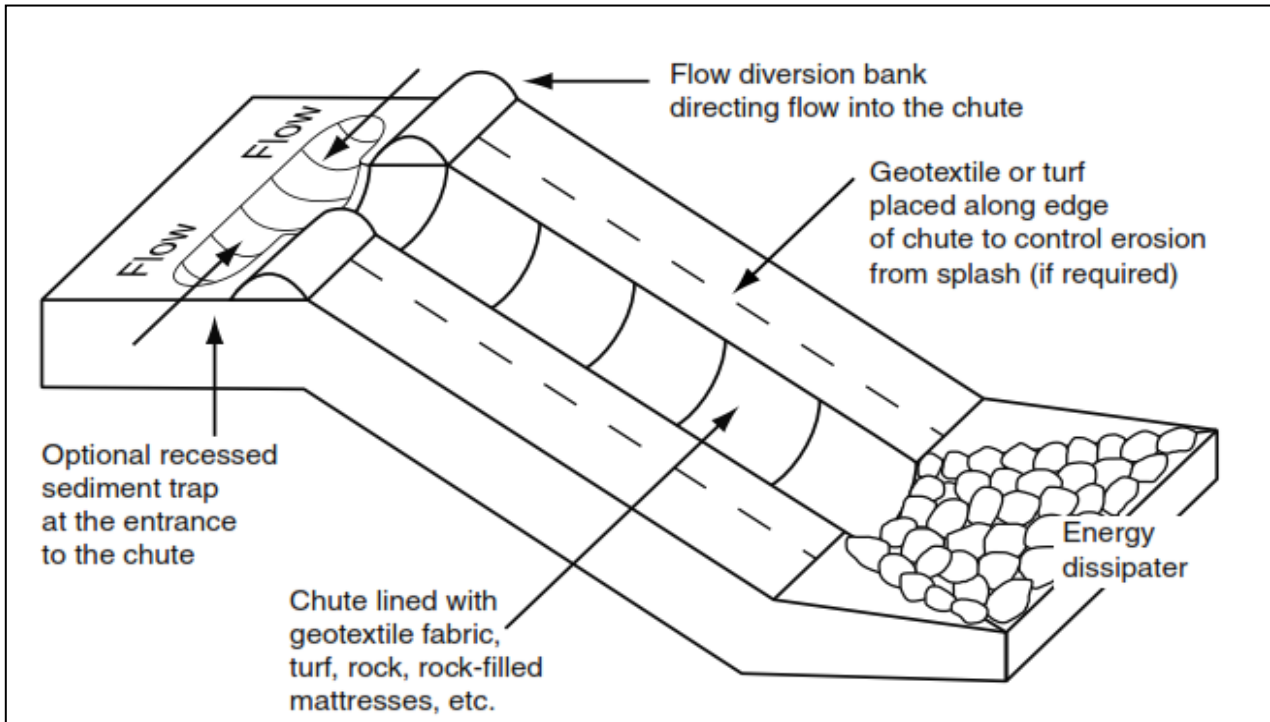

Figure 3-8 and Plate 3-8 Example of Small Rock Shute and Dissipater off a Hardstand.



3.5 Sediment controls

Sediment controls are measures that trap and retain sediments, thereby enabling removal of sediment from the stormwater flow. Where practical, sediment should be trapped close to its source, reducing break-down of soil particles and the release of dispersive clays (if present).

Sediment controls have the greatest maintenance requirements of ESC measures. A sediment control structure may not work properly if it does not have sediment-removal (maintenance) after a storm event.

3.5.1 Sediment fences

Sediment fences provide physical filtration of sheet flow passing through the filter material, and allow settling of suspended sediments by the ponding of water behind the fence. Sediment fences (Figure 3-9) typically:

- Consist of a filter fabric attached to a wire and post fence at a maximum height of 700 mm with an additional 200 mm (min) buried and compacted into an upstream trench;
- Should be constructed along a contour with turn-ups at either end to prevent runoff flowing around the fence;
- Are most effective for coarse-fraction sediments in sheet flows;
- Trap sediment larger than 0.14mm and have little impact on fine silts;
- May be used in the control of sediment runoff from exposed land, unsealed roads, batters and stockpiles; and
- For large areas on moderate slopes, sediment fences may be placed at intervals down-slope with a catch-drain on its downstream side. This will contain sediments at the source and minimise concentration of flow.

For more details on sediment fences refer to:

- Catchments & Creeks fact sheet on sediment fences:
http://www.catchmentsandcreeks.com.au/fact-sheets/fs_sedcontrol_sheetflow.html.
- The International Erosion Control Association (IECA) Australasia publications on sediment fences:
<https://www.austieca.com.au/publications/sediment-control>.

Figure 3-9 Typical Installation of a Sediment Fence (IECA 2008).

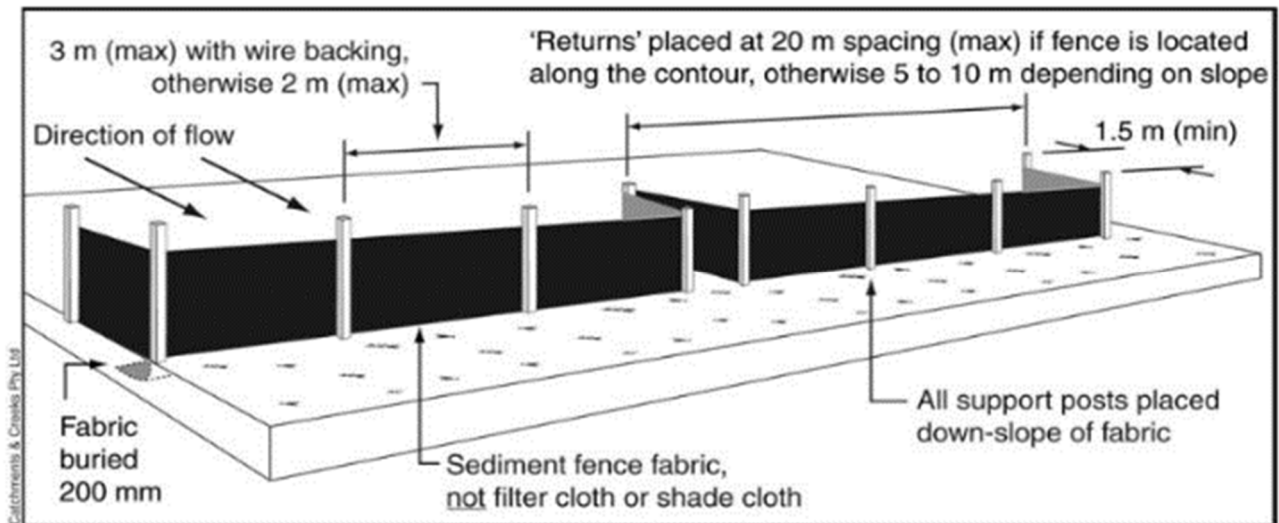

3.6 Mulch filter berms

Mulch filter berms provide physical filtration of sheet flow passing through the filter material, and allow settling of suspended sediments by the ponding of water upslope of the berm (Figure 3-10). Mulch filter berms typically:

- Consist of tub ground material that produces interlocking fibres rather than chipping;
- Should be constructed along a contour; and
- Are most effective for coarse fraction sediments in sheet flows.

For more details on mulch filter berms refer to:

- Catchments & Creeks fact sheet on mulch filter berms:
http://www.catchmentsandcreeks.com.au/fact-sheets/fs_sedcontrol_sheetflow.html.
- The International Erosion Control Association (IECA) Australasia publications on mulch filter berms:
<https://www.austieca.com.au/publications/sediment-control>.

Figure 3-10 Typical Profile and Recommended Maximum Spacing of a Mulch Filter Berm (IECA 2008)

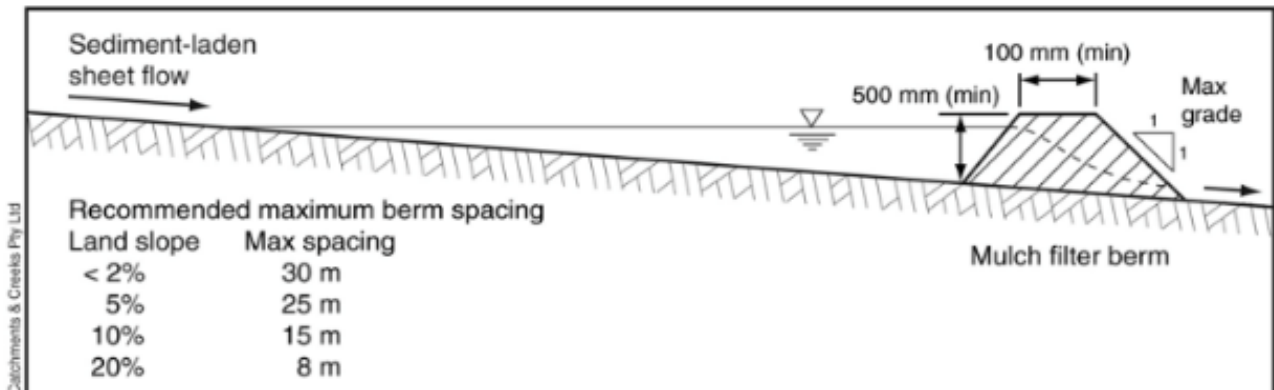

3.7 Stormwater retention basin

A stormwater retention basin (Figure 3-10

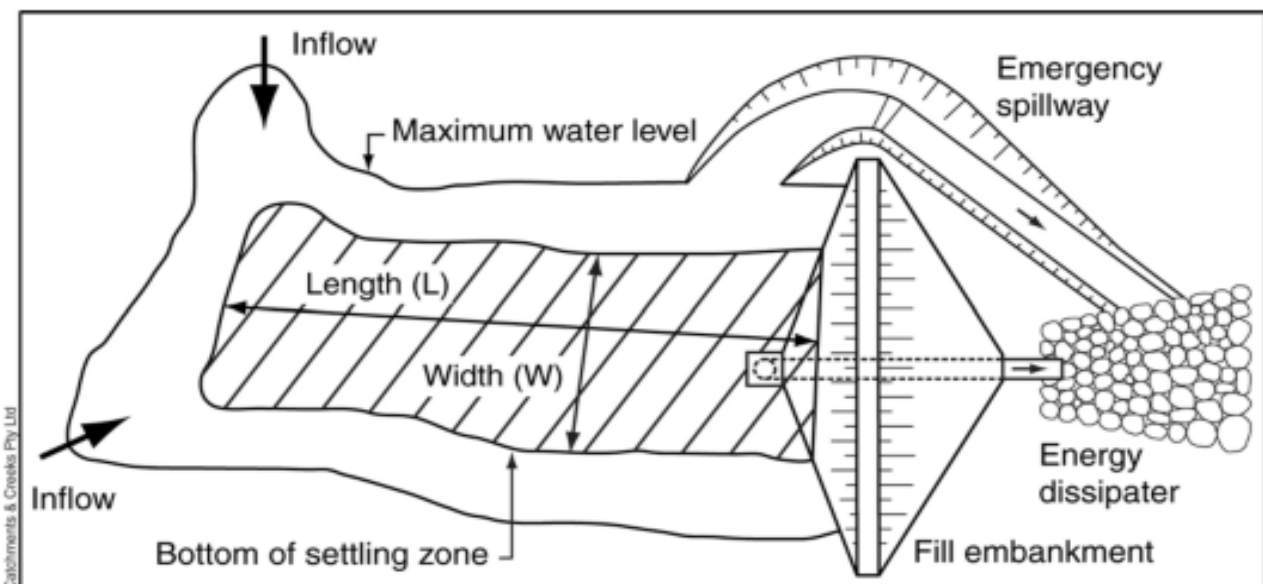

and Figure 3-12) is an effective system to trap and retain a wide range of sediment particle sizes down to 0.045 mm, depending on its hydraulic characteristics (retention time and flow-distribution). It is noted that:

- Stormwater retention basins are usually required when the disturbed area is greater than one hectare, the soils are dispersive and/or there is a need to control runoff turbidity;
- Stormwater retention basins should be located upstream of water bodies, bushland and major stormwater systems;
- Stormwater retention basins are sized to contain and slowly settle fine particles or to slow the flow's velocity allowing settlement of coarser particles during flow-through; and
- Both coarse sediment concentration and turbidity levels can be reduced.



For more details on stormwater retention basin refer to:

- Catchments & Creeks fact sheet on sediment basins :
http://www.catchmentsandcreeks.com.au/fact-sheets/fs_type12controls.html.

Figure 3-11 Typical Profile of a Sediment Basin with Riser Pipe Outlet (IECA 2008)

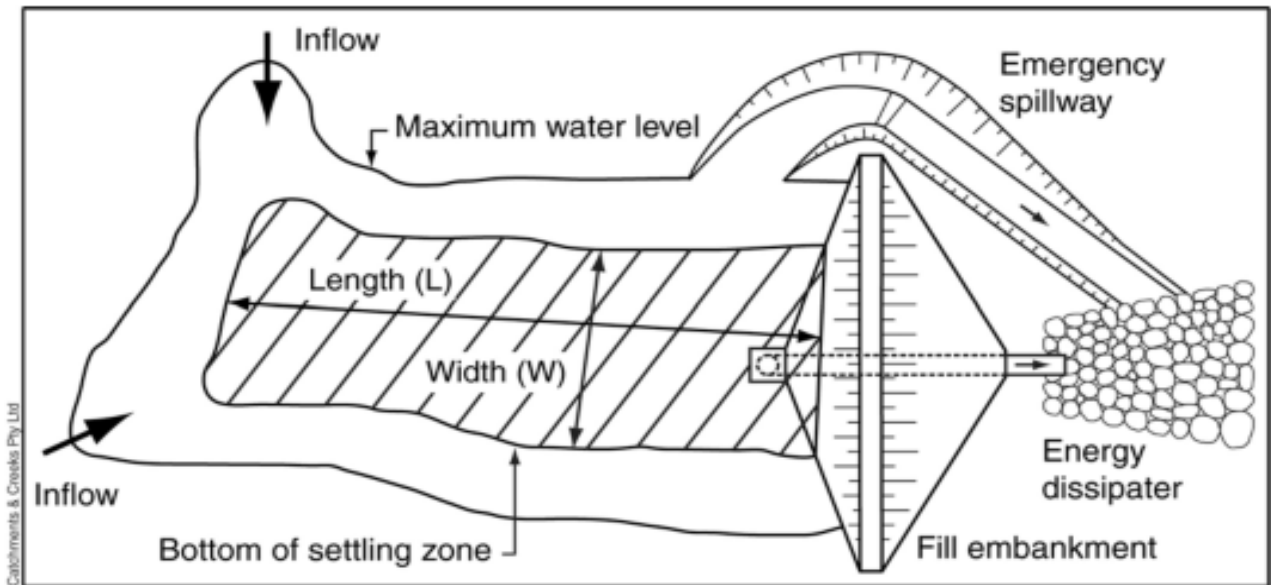
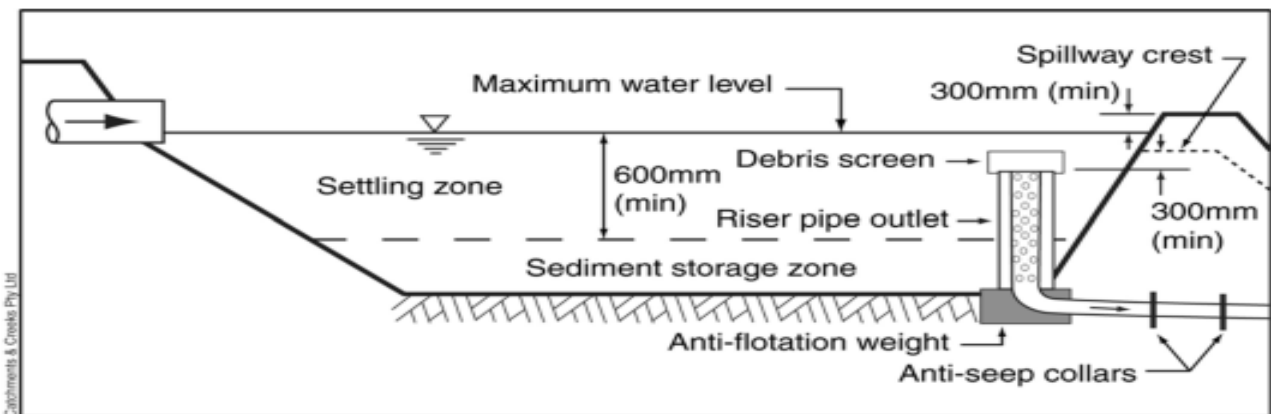

Figure 3-12 Typical Plan View of a Sediment Basin with Riser Pipe Outlet and Energy Dissipater (IECA 2008).



4 Overview of Erosion and Sediment Control Measures

Ground disturbances will be undertaken in accordance with a Land Clearing Permit Procedure (LCPP) (Attachment B in Appendix K). Ground disturbance includes all disturbances to natural ground including borrow pits, drill pads and infrastructure construction easements. Disturbances will be staged to reduce the area of exposed surfaces through the construction and operations phases.

4.1 Ground disturbance process

Where practicable areas requiring clearing should occur during the dry season, rehabilitation and/or sediment control structures should be installed prior to the start of the wet season. Disturbances will be managed in general accordance with the following:

- **Weed Removal**

The area will be surveyed to assess if the vegetation present comprises of any weeds. Weeds will be removed / treated in accordance with the Weed Management Plan (Appendix I) prior to ground disturbances occurring. Weed removal is an important part of the process to ensure mulch does not assist in the distribution of weeds across the site.

- **Vegetation Removal**

Vegetation will be cleared in a manner that minimises damage to any retained vegetation. Cleared vegetation will be mulched and stockpiled. The stockpiled vegetation will either be used during revegetation of the area or for storage/covering top soil stockpiles.

- **Flow Diversion Bank**

Flow diversion banks will be installed if required to facilitate the diversion of clean water around the disturbance. The banks will have a level spreader to discharge.

- **Topsoil Removal**

Following the installation of flow diversion banks if required, topsoil will be removed and stockpiled adjacent to the disturbance area. The topsoil will be utilised as part of the revegetation process for the disturbance or transferred to the topsoil stockpiles.

- **Sediment Fence**

If the topsoil is intended to be reused at the area of ground disturbance, the stockpile is to be located within the disturbance area and associated flow diversion bank. In addition, a sediment fence is to be installed on the down gradient side of the stockpile.

- **Surface Roughening / Contour Ripping**

The flow diversion bank will be removed / flattened. Roughening will then be undertaken to facilitate vegetation establishment and reduce potential for rill and gully erosion. Following roughening/ridge installation the areas will be immediately seeded and mulched to optimise seed germination and growing conditions.

- **Revegetation**

Where possible, areas will be revegetated immediately following the completion of works with native species. If revegetation is not established sufficiently due to gradient complications then a CCS may be installed to arrest soil movement and facilitate vegetation establishment.

4.2 Mount Todd Project Area

The MTPA is expected to go through three main phases during the LOM. The first phase will be some mining and stockpiling during the construction of infrastructure. The second phase will mining and processing the ore from the open pit operation. The third phase will be decommissioning and rehabilitation of the site. Based on current known data the mine will have a life of around 20 years inclusive of construction, operations and closure.

4.2.1 Open pit

Haul roads constructed across the MTPA will potentially also serve as flow diversion banks. The pit perimeter haul roads and berms will restrict overland flows entering the pit. The remaining haul roads across the site will have culverts or floodways' installed to facilitate overland flow through the site.

At the pit closure stage, flow diversion banks/berms will become part of the abandonment bunds. The diversion banks/berms will continue to operate as an impermeable core to the abandonment bund, however the following modifications will be made:

- Expanded to minimum dimension of 2m height and 5m wide base; and
- Developed with unweathered (geochemically stable) freely draining waste rock.

4.2.2 Waste rock dump

An expansion of the existing waste rock dump (WRD) will be constructed to restrict Acid Mine Drainage. If required, catch drains will be constructed adjacent to the WRD base and act as a perimeter drain collecting surface flows and transferring them to RP1. The catch drains will be installed with check dams to reduce flow velocities. A bund will be positioned on the 'outside' of the catch drain to restrict other water sources entering the drain.

Once the WRD reaches capacity it will be covered with a water sheading cap. The following ESC measures will be implemented at the WRD:

- The cover will be revegetated with native species to minimise erosion of the WRD surface. If revegetation is not established sufficiently on batters a CCS may be installed to arrest soil movement and facilitate vegetation establishment;
- Flow diversion banks made from stabilised topsoil and/or geotextile will transfer flows around the top of the WRD to rock lined chute(s). The diversion banks primary use is to reduce the potential for rill and subsequent gully erosion of the batters;

- Rock lined chutes may be installed on the WRD to transfer runoff water from the top of WRD to ground level. The chutes primary role is to reduce the potential for erosion of the batters and transfer flows into an energy dissipater. It should however be noted that WRD design preference will be to manage runoff water from the top of the WRDs by establishing a store and release system that encourages infiltration along with perimeter bunding and inner swales (i.e. bunded cells) breaking up catchment areas across the top of WRD; and
- Energy dissipaters will collect flows from rock lined chutes. The structures are designed to significantly reduce flow velocity and therefore erosion potential. In order for flows to be discharged effectively to the surrounding environment a recessed rock pad will be utilised to reduce potential for scour.

4.2.3 Run-of-Mine Pad

The Run- of-Mine (ROM) Pad will have a raised compacted base with a target permeability of 5×10^{-8} m/s. A flow diversion bank will be installed along the perimeter of the ROM Pad to transfer flows to the stormwater basin and the pad itself will have a gentle gradient to the basin. The stormwater basin will be designed to be impermeable and to capture a 1:100 year ARI 72 hour storm event.

The ROM Pad base material has the potential to be geochemically impacted throughout the LOM and as such the closure methods are dependent upon the chemistry of the base at closure. The base will be considered chemically unsuitable if it exhibits levels of contaminants in excess of baseline, ecological trigger values (NEPM 2013) or site specific guidelines for vegetation growth.

All or part of the ROM Pad which is considered geochemically unstable will be removed and disposed of within the WRD. If the material is stable it will be removed and utilised as part of the closure cover on surrounding infrastructure.

4.2.4 Unsealed and sealed tracks

Ground disturbances for the construction of unsealed and sealed tracks will be undertaken in accordance with the ground disturbance process described in Section 4.1 4.1Ground disturbance process. Disturbances will be staged to reduce the area of exposed surfaces susceptible to erosion.

The flow diversion banks installed as part of the clearing procedure will remain in situ until sufficient site drainage has been established. Tracks will be constructed to facilitate effective drainage with a targeted cross fall of 4% (1 in 25). Drainage will be installed adjacent to tracks including:

- Table drains to collect drainage from the surrounding environment and road. The drains will be installed with check dams to reduce water velocities; and
- Diversion drains will be installed and pushed out into the surrounding environmental to facilitate the disposal/discharge of flows into the table drains. The drains are to discharge water via a level spreader or the final grade should be 0.2% for 30 m (i.e. 6cm fall over 30m).

At the time of mine closure or when unsealed and sealed tracks become redundant the following will occur:

- Surface roughening/contour ripping will be undertaken to facilitate vegetation establishment and reduce potential for rill and gully erosion. Following roughening/ridge installation the areas will be immediately seeded and mulched to optimise seed germination and growing conditions; and

Where possible, areas will be revegetated following the completion of works with native species, understanding that results may not be apparent until seasonal rainfall occurs. If revegetation is not established sufficiently due to gradient complications, then a CCS may be installed to arrest soil movement and facilitate vegetation establishment.

4.2.5 Plant growth medium storage

Plant growth medium (PGM) storage areas have been identified to facilitate progressive rehabilitation during mine closure. During ground disturbance all PGM will be collected and stockpiled. The PGM will be utilised for progressive rehabilitation as required.

PGM stockpiles will require ESC measures to be installed to increase stability and reduce degradation. The measures to be used include:

- A sediment fence will be installed surrounding the down gradient area of the stockpile. The sediment fence will be removed following the establishment of vegetation which will enhance the stockpiles stability;
- Surface roughening will occur across the top of the PGM stockpile to facilitate vegetation establishment and reduce potential for rill and gully erosion. Following roughening/ridge installation the areas will be immediately seeded and mulched to optimise seed germination and growing conditions;
- The top of the stockpile will be progressively revegetated with native species to minimise erosion. The revegetation will act as a trial for the closure of the MTPA and identify species which are likely to withstand the surrounding environmental conditions. If revegetation is not established sufficiently on batters a CCS may be installed to arrest soil movement and facilitate vegetation establishment; and
- An up-gradient flow diversion bank will be installed with a level spreader outlet. If there are repeat occurrences of the stockpile toe eroding, then a flow diversion bank will be extended along the length of the stockpile.

4.2.6 Building infrastructure

Clearing areas for mining services buildings will be undertaken in accordance with the ground disturbance process described in Section 4.1 Ground disturbance process.

Following the removal of vegetation, gravelling will be installed across the areas proposed for buildings and light vehicle parking. To reduce surface runoff from the surrounding areas flow diversion banks with level spreader outlets will be installed up gradient of gravelled areas.

A stormwater basin will be installed to collect overland flow from precipitation falling directly on the Mining Services compound/area. A catch drain will be installed down gradient of gravelled areas to transfer to stormwater basins. The stormwater basins will be designed to capture a 1:100 year ARI 72 hour storm event. The basin will be impermeable with a target permeability of 5×10^{-8} m/s.

4.2.7 Horseshoe Creek and Batman Creek realignment

Horseshoe and Batman Creek will be permanently realigned to divert flows around the expansion of the Tailings Storage Facility 2 footprint. The realignment locations are detailed in Section 4.6 of the Mine Management Plan (MMP). The detailed design of the realignment is yet to be completed.

4.2.8 Process plant

Ground disturbances for the construction of the process plant will be undertaken in accordance with the ground disturbance process described in Section 4.1 Ground disturbance process.

Disturbances will be staged to reduce the area of exposed surfaces susceptible to erosion. Following the removal of vegetation, gravelling will be installed across the areas proposed for modular buildings and light vehicle parking. To reduce surface runoff from the surrounding areas, if required, flow diversion banks with level spreader outlets will be installed up gradient of the gravelled areas.

A stormwater basin will be installed to collect overland flow from precipitation falling directly on the Processing Site compound/area. A catch drain will be installed down gradient of gravel sheeted areas to transfer to stormwater basins. The stormwater basin will be designed to capture a 1:100 year ARI 72 hour storm event. The basin will be impermeable with a target permeability of 5×10^{-8} m/s.

4.2.9 Power station

Ground disturbances for the construction of the power station will be undertaken in accordance with the ground disturbance process described in Section 4.1 Ground disturbance process. Disturbances will be staged to reduce the area of exposed surfaces susceptible to erosion.

Following the removal of vegetation, gravelling will be installed across the areas proposed for modular buildings, the power station and light vehicle parking. To reduce surface runoff from the surrounding areas flow diversion banks with level spreader outlets will be installed up gradient of the gravelled area.

A stormwater basin will be installed to collect overland flow from precipitation falling directly on the power station compound/area. A catch drain will be installed down gradient of gravelled areas to transfer to stormwater basins. The stormwater basin will be designed to capture a 1:100 year ARI 72 hour storm event. The basin will be impermeable with a target permeability of 5×10^{-8} m/s.

4.2.10 Tailings storage facilities and ponds

As part of the closure and rehabilitation, the Tailings Storage Facilities (TSF) and ponds will be progressively rehabilitated. The TSF and ponds will be capped with a low permeability soil, a layer of waste rock and ESC measures will include:

- The cover will be revegetated with native species to minimise erosion of the cap;
- Flow diversion banks made from stabilised topsoil and/or geotextile will transfer flows around the top of the facilities to rock lined chute(s). The diversion banks primary use is to reduce the potential for rill and subsequent gully erosion of the batters;
- Rock lined chutes may be installed at facilities to transfer runoff water from the top of the TSFs to ground level. The chutes primary role is to reduce the potential for erosion of the batters and transfer flows into an energy dissipater. It should however be noted that TSF design preference will be to manage runoff water from the top of the TSFs by establishing a store and release system that encourages infiltration along with perimeter bunding and inner swales (i.e. bund walls) breaking up catchment areas across the top of TSFs; and
- Energy dissipaters will collect flows from rock lined chutes. The structures are designed to significantly reduce flow velocity and therefore erosion potential. In order for flows to be discharged effectively to the surrounding environment a recessed rock pad will be utilised to reduce potential for scour.

4.3 Construction camp

Ground disturbance for the construction of accommodation village will be undertaken in accordance with the ground disturbance process described in Section 4.1 Ground disturbance process. Disturbances will be staged to reduce the area of exposed surfaces susceptible to erosion.

Following the removal of vegetation, gravelling will be installed across the areas proposed for modular buildings and light vehicle parking. To reduce surface runoff from the surrounding areas flow diversion banks with level spreader outlets will be installed up gradient of the gravelled area.

A stormwater basin may be installed to collect overland flow from precipitation falling directly on the accommodation village compound/area. A catch drain will installed down gradient of gravelled areas to transfer to stormwater basins. The stormwater basin will be designed in the detailed design phase.

The construction camp will be removed once the processing plant has been completed and operational. The camp area footprint will then be incorporated into mining operations and will possibly be used as laydown yards or other as yet decided purposes.



5 Maintenance Requirements

- The ESCMP for the proposed mine development is prepared with the following maintenance philosophy:
- Selection of mitigation measures requiring minimal regular maintenance or simple maintenance procedures; and
- Access must be provided if maintenance is required on any structure.

A maintenance program for the ESC measures is outlined in [Table 5-1](#). A checklist will be developed that records maintenance problems likely to occur for each of the ESC measures adopted and identifies the person responsible for implementing, maintaining, inspecting, repairing and modifying controls.

The inspection frequency will need to be adjusted according to the prevailing weather conditions, i.e. increased during wet periods and reduced during dry periods. Weekly inspections will be sufficient during minor runoff events. An inspection is required after any major runoff event.



Table 5-1 Erosion and Sediment Control Maintenance Requirements

Item	Inspection Frequency	Maintenance Frequency	Maintenance Activities
Erosion Control			
Flagging	As required; or daily during clearances.	As required.	Identify any damage and re-establish flagging.
Revegetation	As required or after a major rainfall event.	When areas of mulch have been eroded or if vegetation does not establish in the required time.	<ul style="list-style-type: none"> • Re-application of mulch and take action to prevent future damage. • Assess if vegetation has established and to identify if any erosion, channelling or weed problems occur. • Reseeding and weeding to maintain a dense, vigorous growth of vegetation. • Vegetation and mulch will require reestablishment if less than 70% is present. • Application of additional mulch as required. • Maintenance of any upslope diversion channels or protective fences if installed.
Gravelling	As required or after a major rainfall event.	As required.	<ul style="list-style-type: none"> • Check for continuous even cover and for rilling along the up-gradient slope edges. • Replace gravel from the down-gradient location(s).
Cellular Confinement System	As required or after a major rainfall event.	As required.	Removal and reinstallation of system and/or growth media.
Surface Roughening/Contour Ripping	As required or after a major rainfall event.	As required.	If rill erosion occurs through ridges the rills are to be filled.
Soil Binders	As required or after a major rainfall event.	As required.	If evidence of damage to soil bound surface leading to erosion, soil binder to be reapplied and other ESC measures to be implemented.
Drainage Controls			



Item	Inspection Frequency	Maintenance Frequency	Maintenance Activities
Flow Diversion Bank	As required during the wet season or after a major rainfall event.	When slumps, wheel track damage or loss of freeboard has occurred. When litter or sediment has accumulated and filled 30% of the drain depth.	<ul style="list-style-type: none"> Identify any damaged or eroded areas due to sediment accumulated in the channel, vehicular damage to the banks, settlement of banks and/or scour due to excessive flow velocity. Remove accumulated litter and sediment. Reform bund or channel banks to design grade.
Catch Drain	As required during the wet season or after a major rainfall event.	Damage of the channel banks has occurred.	<ul style="list-style-type: none"> Identify any damaged or eroded areas due to sediment accumulated in the channel, vehicular damage to the banks, settlement of banks and/or scour due to excessive flow velocity. Remove accumulated litter and sediment. Reform bund or channel banks to design grade.
Table Drain	Biannually	When litter has accumulated or sediment has filled 30% of the drain depth.	<ul style="list-style-type: none"> Identify any damaged or eroded areas due to sediment accumulated in the channel, vehicular damage, settlement of banks and/or scour due to excessive flow velocity. Remove accumulated litter and sediment. Reform bund or channel banks to design grade.
Diversion Channels	Biannually	When litter has accumulated or sediment has filled 30% of the drain depth.	<ul style="list-style-type: none"> Identify any damaged or eroded areas due to sediment accumulated in the channel, vehicular damage, settlement of banks and/or scour due to excessive flow velocity. Remove accumulated litter and sediment. Reform bund or channel banks to design grade.
Check Dam	As required during the wet season or after a major rainfall event.	When litter has accumulated or sediment has filled 30% of the dam depth.	<ul style="list-style-type: none"> Identify any damage or sediment build-up. Re-establish dams when sediment begins to flow through the structure. Remove accumulated litter and sediment.
Level Spreader	As required during the wet season or after a major rainfall event.	When sediment build-up limits the spreader to function effectively Scouring of channel and vegetation damaged.	<ul style="list-style-type: none"> Identify any damage or sediment build-up causing concentration flow. Reformation of channel banks to design grade. Treat scouring or channel damage upstream of the spreader. Application of additional mulch or vegetation.



Item	Inspection Frequency	Maintenance Frequency	Maintenance Activities
			<ul style="list-style-type: none"> Remove accumulated litter and sediment.
Temporary Watercourse Crossing	As required during the wet season or after a major rainfall event.	When damage or excessive scour has occurred.	<ul style="list-style-type: none"> Debris trapped on or upstream of the crossing is removed. Identify and remediate any erosion upstream or downstream scour.
Rock Lined Chute	As required during the wet season or after a major rainfall event.	As required.	<ul style="list-style-type: none"> Check flow entry condition to ensure no flow is bypassing the chute(s). Check for inlet scour, piping or bank failures. Check whole of structure for rill or gully erosion to ensure chutes are operating efficiently.
Energy Dissipater and Recessed Rock Pad (Outlet Structure)	As required during the wet season or after a major rainfall event.	As required.	<ul style="list-style-type: none"> Identify any erosion around the edge of the pad and ensure rocks remain adequately recessed into the earth. Check for excessive displacement of rocks and potential for reinstatement.
Sediment Controls			
Sediment Fence	As required during the wet season or after a major rainfall event.	When sediment accumulates at the base of the control structure or when permeability is excessively reduced.	<ul style="list-style-type: none"> Identify any damage caused by on-site by excessive sediment movement. Remove accumulated litter and sediment. Reform sediment fence, take action to prevent future damage. Where fence is regularly damaged, reassess and reduce the area of inflow, install a second fence at least 1 m downslope of the existing fence.
Sediment Basin	As required during the wet season or after a major rainfall event.	When litter has accumulated or sediment has filled 10% of the sediment basin volume.	<ul style="list-style-type: none"> Remove accumulated litter and sediment, spreading it well away from drainage lines. Repair of any scouring damage to inlet and outlet and embankment vegetation. Pump-out of retained water to maintain capacity for subsequent inflow events.

6 Monitoring

During the wet season all ERSED controls will be monitored after every rain event to ensure that any damage does not escalate to a point that remedial work will be extensive and costly. A monitoring checklist will be maintained for all ESC measures, with entries made as inspections are completed and after rainfall events on:

- Condition of ESC structures and stabilised surfaces;
- Repair of any damage to ESC structures; and
- Rainfall, including duration and times.

Corrective actions will be investigated and implemented within 24 hours where practicable where findings of the ESC monitoring indicate a non-conformance.

7 Reporting, Auditing and Review

Vista Gold will undertake and provide any reporting, auditing and reviews that may be required for the management of erosion and sediment control.

- Vista Gold will conduct environmental workplace inspections on the facilities that are under their control. Corrective actions will be recorded in the sites EMS. A corrective actions report can be provided on request;
- Vista Gold will collect, and store water quality data and this data will be available on request;
- Vista Gold and its Sub-contractors will continue to conduct internal audits as required. Findings of audits will be available on request;
- All environmental and/or safety incidents associated with infrastructure or activities will be reported to Contractor; and
- Detailed management documentation, for example plans and procedures, will be reviewed periodically to ensure that they remain applicable to current operations and compliant with the requirements of the regulatory authorities.





8 Incident Reporting

All environmental incidents on site will be reported as per the requirements of Environmental Incident Reporting under Section 29 of the *Mining Management Act* (2001). Any environmental incident deemed to be of any significant nature will be detailed in a formal Incident Report and submitted to the DPIR. Under Section 29 an incident must be reported as soon as practicable. Vista Gold will provide a verbal report of an incident within 24 hours and provide a written report within 7 days unless instructed by the Department otherwise.

All environmental incidents off site but are associated with Vista Gold's activities at the MTPA will be reported to the NT EPA under Section 14 of the *Waste Management and Pollution Control Act* (1998). Notification must be received by the EPA within 24hrs. A written response must be received by the EPA within 7 days.

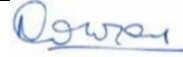
File Name: *Appendix N- Erosion and Sediment Control Plan.docx*

Document Status

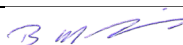
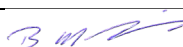
Revision	Author	Reviewer		Approved for Issue		
		Name	Signature	Name	Signature	Date
REV A	John Ross	Nicole Conroy		Jill Woodworth		15/11/2017
REV 0	James Hill	Jill Woodworth		Jill Woodworth		16/11/2017
REV 1	Brent Murdoch	John Rozelle		Brent Murdoch		31/10/2018
Rev 2	Julia Curran	Jill Woodworth		Brent Murdoch		07/08/2020
Rev 3	Brent Murdoch	John Rozelle		Brent Murdoch		23/05/2022



www.mttodd.com.au



Mount Todd Project Area

Erosion and Sediment Control Management Plan
